



INSULATED TUBING & PIPE SUPPORTS PLUMBING COMPONENTS

CUSH-A-NATOR®



(CN) Standard Temp
-50°F to 275°F

(HT) High Temp
-65°F to 340°F

(HIT) High Intensity Temp
-65°F to 400°F

CUSH-A-BLOCK® / MINI



GAMMA PADS

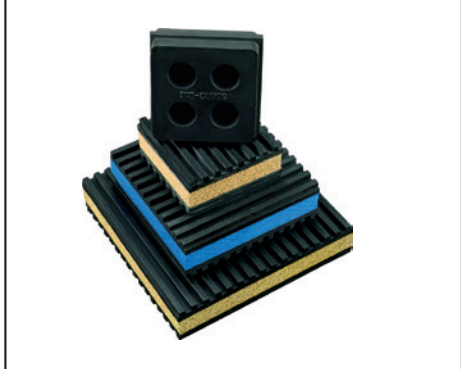

CUSH-A-THERM®

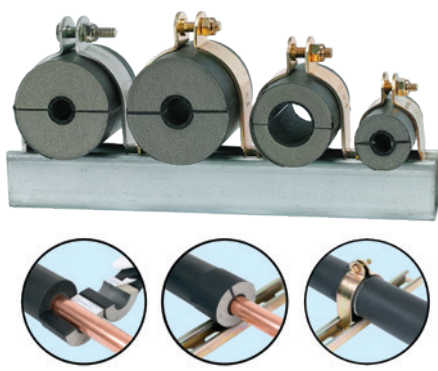

SNAP-A-SADDLE PRO™



SNAP-A-SADDLE PRO™ MULTI



ZBA Z-BRACKET

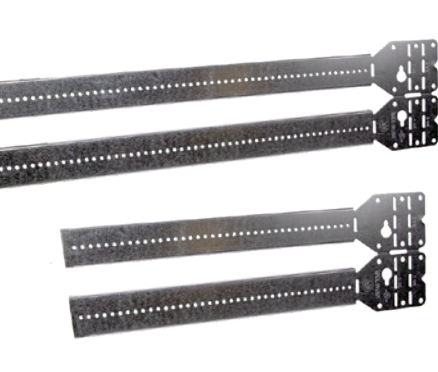

FITTINGS & ACCESSORIES

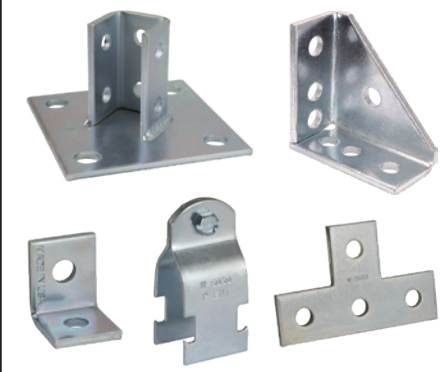

CUT-STRUT

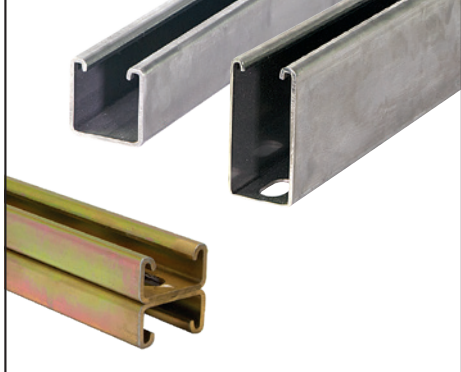

Wesanco-ZSi.com | 800-323-7053

ZSi & Wesanco are part of the Ideal Tridon Group. Learn more at idealtridongroup.com



tjfhvac.com

TJF Company
3434 Sunbrite Dr.
Covington, KY 41015
859-363-0000



WESANCO

ZSI

INSULATED TUBING & PIPE SUPPORTS HVAC REFRIGERATION COMPONENTS

CUSH-A-NATOR®



(CN)	(HT)	(HIT)
Standard Temp	High Temp	High Intensity
-50°F to 275°F	-65°F to 340°F	Temp
		-65°F to 400°F

CUSH-A-BLOCK®



CUSH-A-BLOCK® MINI



CUSH-A-THERM®

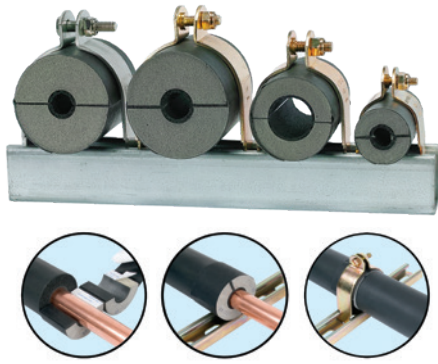

SNAP-A-SADDLE PRO™



SNAP-A-SADDLE PRO™ MULTI



LOOP CLAMPS



FITTINGS & ACCESSORIES



CUT-STRUT

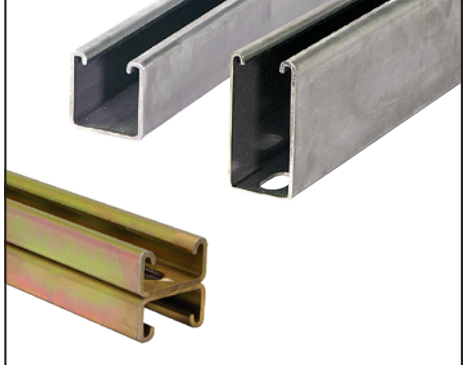

Wesanco-ZSi.com | 800-323-7053

Zsi & Wesanco are part of the Ideal Tridon Group. Learn more at idealtridongroup.com



tjfhvac.com

TJF Company
3434 Sunbrite Dr.
Covington, KY 41015
859-363-0000

Scott Robinson
Ohio, Chicago, Indianapolis
3434 Sunbrite Dr • Covington, KY 41015
scott@tjfhvac.com • 937-604-6411

INSULATED TUBING & PIPE SUPPORTS HVAC REFRIGERATION COMPONENTS

CUSH-A-NATOR®



(CN) Standard Temp
-50°F to 275°F

(HT) High Temp
-65°F to 340°F

(HIT) High Intensity Temp
-65°F to 400°F

CUSH-A-BLOCK®



CUSH-A-BLOCK® MINI

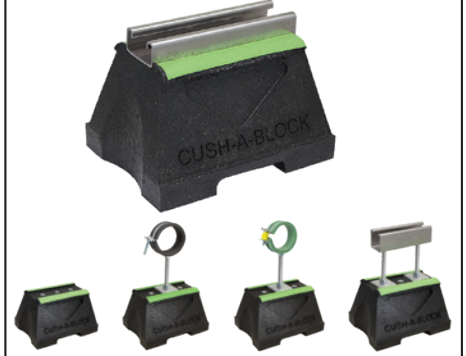

CUSH-A-THERM®

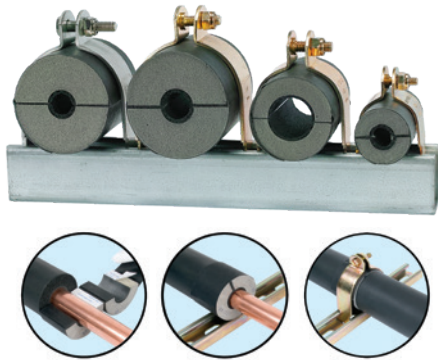

SNAP-A-SADDLE PRO™



SNAP-A-SADDLE PRO™ MULTI



LOOP CLAMPS



FITTINGS & ACCESSORIES

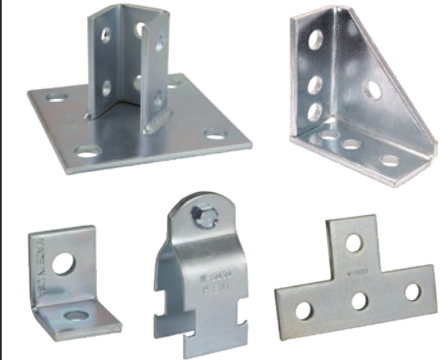

CUT-STRUT



Wesanco-ZSi.com | 800-323-7053

ZSi & Wesanco are part of the Ideal Tridon Group. Learn more at idealtridongroup.com



TJF Company
3434 Sunbrite Dr.
Covington, KY 41015
859-363-0000

Jacob Robinson
Business Development Manager
Kentucky, Tennessee
939 Oakmont Ct • Union, KY 41091
jacob@tjfhvac.com • 859-802-8784

INSULATED TUBING & PIPE SUPPORTS HVAC REFRIGERATION COMPONENTS

CUSH-A-NATOR®



(CN) Standard Temp
-50°F to 275°F

(HT) High Temp
-65°F to 340°F

(HIT) High Intensity Temp
-65°F to 400°F

CUSH-A-BLOCK®



CUSH-A-BLOCK® MINI

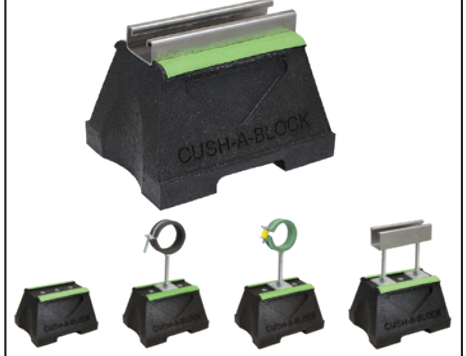

CUSH-A-THERM®

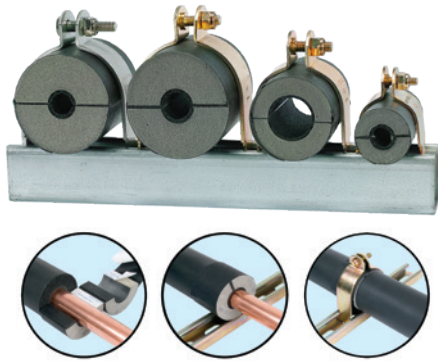

SNAP-A-SADDLE PRO™



SNAP-A-SADDLE PRO™ MULTI



LOOP CLAMPS



FITTINGS & ACCESSORIES

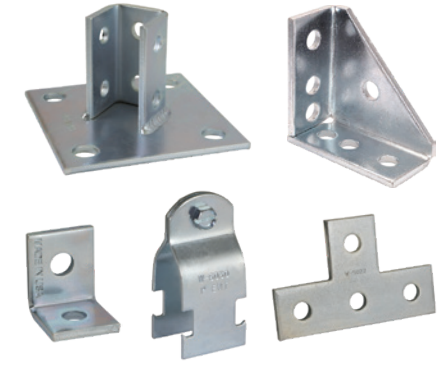

CUT-STRUT



Wesanco-ZSi.com | 800-323-7053

ZSi & Wesanco are part of the Ideal Tridon Group. Learn more at idealtridongroup.com



TJF Company
3434 Sunbrite Dr.
Covington, KY 41015
859-363-0000

Mike Szajda
Business Development Manager
Minnesota, Wisconsin, North & South Dakota, N Illinois
2591 Meadowlark Dr • West Chicago, IL 60185
mike@tjfhvac.com • 937-654-9448

INSULATED TUBING & PIPE SUPPORTS HVAC REFRIGERATION COMPONENTS

CUSH-A-NATOR®



(CN) Standard Temp
-50°F to 275°F

(HT) High Temp
-65°F to 340°F

(HIT) High Intensity Temp
-65°F to 400°F

CUSH-A-BLOCK®



CUSH-A-BLOCK® MINI

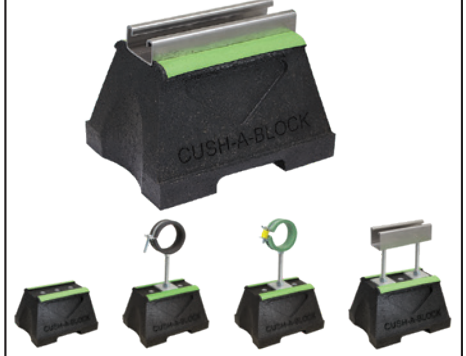

CUSH-A-THERM®

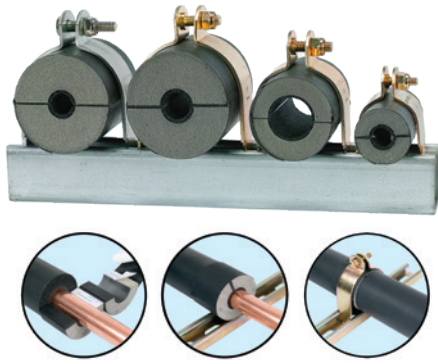

SNAP-A-SADDLE PRO™



SNAP-A-SADDLE PRO™ MULTI

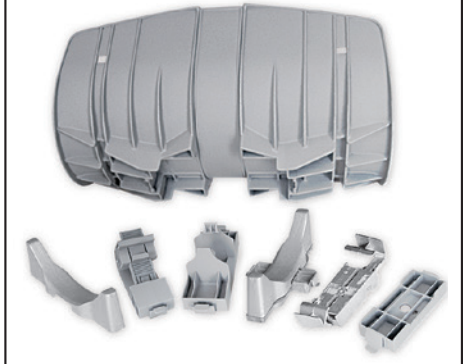

LOOP CLAMPS



FITTINGS & ACCESSORIES

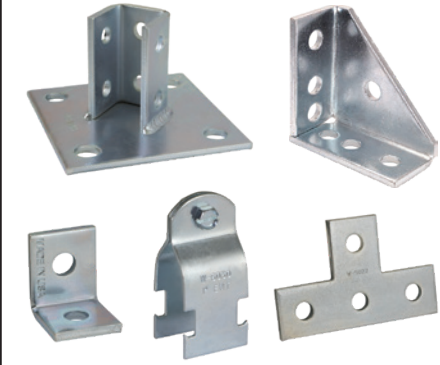

CUT-STRUT

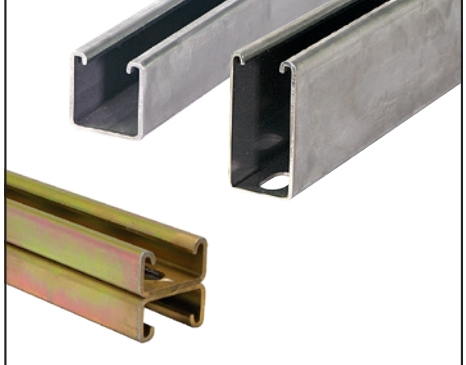

Wesanco-ZSi.com | 800-323-7053

ZSi & Wesanco are part of the Ideal Tridon Group. Learn more at idealtridongroup.com



INSULATED TUBING & PIPE SUPPORTS HVAC REFRIGERATION COMPONENTS

CUSH-A-NATOR®



(CN) Standard Temp
-50°F to 275°F

(HT) High Temp
-65°F to 340°F

(HIT) High Intensity Temp
-65°F to 400°F

CUSH-A-BLOCK®



CUSH-A-BLOCK® MINI

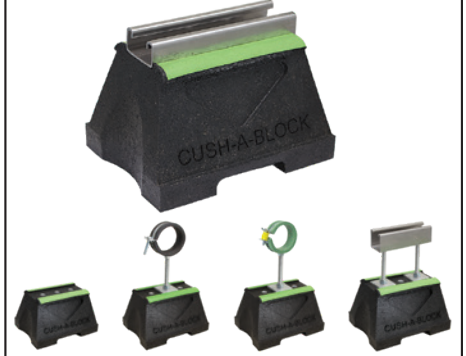

CUSH-A-THERM®

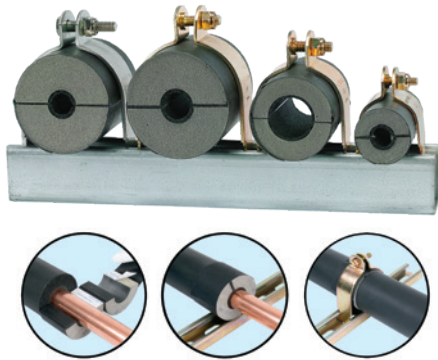

SNAP-A-SADDLE PRO™



SNAP-A-SADDLE PRO™ MULTI



LOOP CLAMPS



FITTINGS & ACCESSORIES

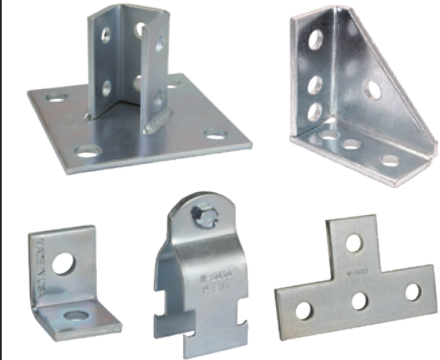

CUT-STRUT



Wesanco-ZSi.com | 800-323-7053

ZSi & Wesanco are part of the Ideal Tridon Group. Learn more at idealtridongroup.com



TJF Company
3434 Sunbrite Dr.
Covington, KY 41015
859-363-0000

Shawn Davis
Business Development Manager
Michigan, N Indiana, N Illinois
1408 Egleston Ave • Kalamazoo, MI 49001
shawn@tjfhvac.com • 616-238-3100

INSULATED TUBING & PIPE SUPPORTS HVAC REFRIGERATION COMPONENTS

CUSH-A-NATOR®



(CN) Standard Temp
-50°F to 275°F

(HT) High Temp
-65°F to 340°F

(HIT) High Intensity Temp
-65°F to 400°F

CUSH-A-BLOCK®



CUSH-A-BLOCK® MINI

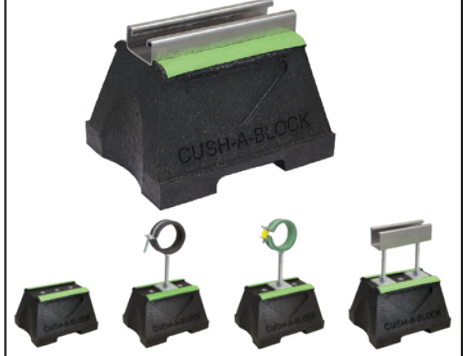

CUSH-A-THERM®

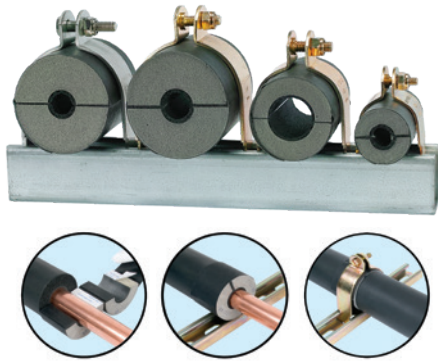

SNAP-A-SADDLE PRO™



SNAP-A-SADDLE PRO™ MULTI



LOOP CLAMPS



FITTINGS & ACCESSORIES

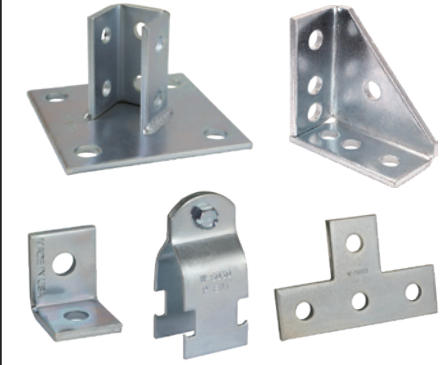

CUT-STRUT

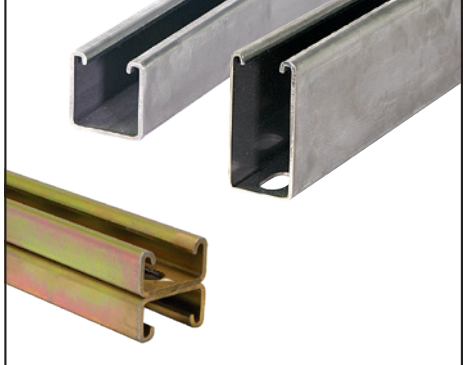

Wesanco-ZSi.com | 800-323-7053

ZSi & Wesanco are part of the Ideal Tridon Group. Learn more at idealtridongroup.com



TJF Company
3434 Sunbrite Dr.
Covington, KY 41015
859-363-0000

Tom Spritzky
Business Development Manager
Indiana, S Illinois
2821 Campus Dr • Crestview Hills, KY 41017
tom@tjfhvac.com • 859-322-1575



WESANCO

ZSI

INSULATED TUBING & PIPE SUPPORTS HVAC REFRIGERATION COMPONENTS

CUSH-A-NATOR®



(CN)	(HT)	(HIT)
Standard Temp	High Temp	High Intensity
-50°F to 275°F	-65°F to 340°F	Temp
		-65°F to 400°F

CUSH-A-BLOCK®



CUSH-A-BLOCK® MINI

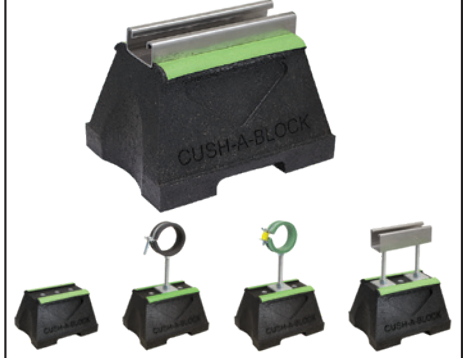

CUSH-A-THERM®

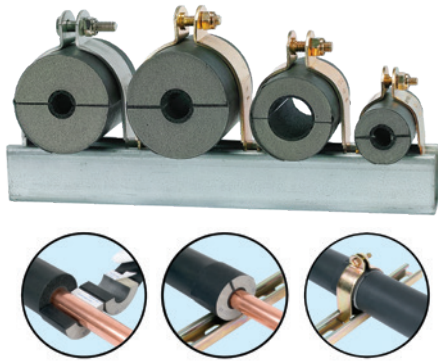

SNAP-A-SADDLE PRO™



SNAP-A-SADDLE PRO™ MULTI

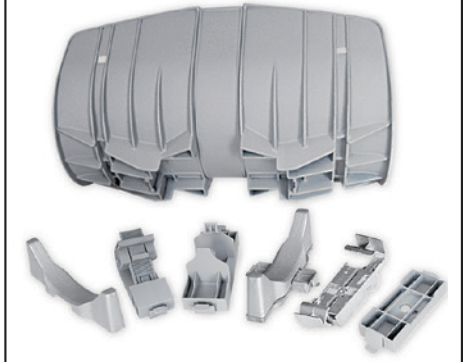

LOOP CLAMPS



FITTINGS & ACCESSORIES

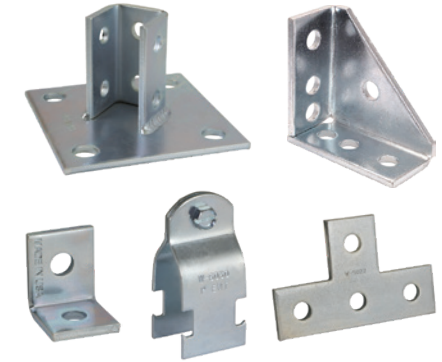

CUT-STRUT

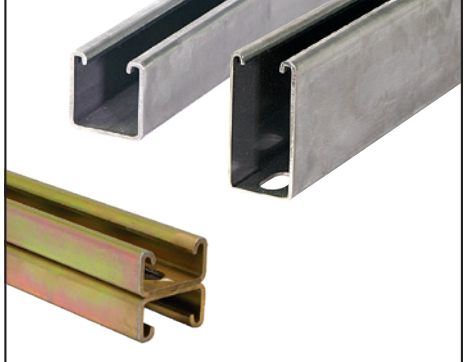

Wesanco-ZSi.com | 800-323-7053

ZSi & Wesanco are part of the Ideal Tridon Group. Learn more at idealtridongroup.com



Max Weger
 ZSi-Foster Regional Sales Manager
 Cell: 734-502-8522 • max@zsi-foster.com
www.zsi-foster.com

INSULATED TUBING & PIPE SUPPORTS PLUMBING COMPONENTS

CUSH-A-NATOR®



(CN) Standard Temp -50°F to 275°F
 (HT) High Temp -65°F to 340°F
 (HIT) High Intensity Temp -65°F to 400°F

CUSH-A-BLOCK® / MINI



GAMMA PADS

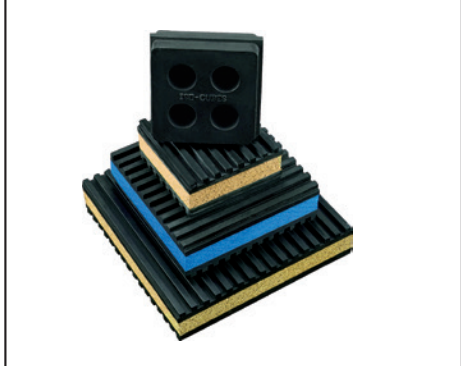

CUSH-A-THERM®

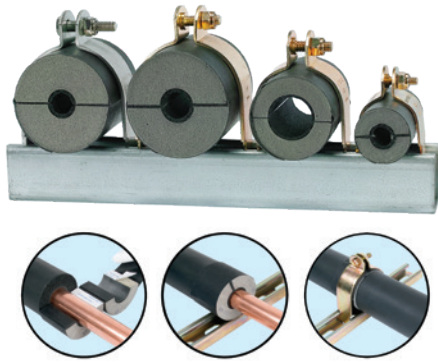

SNAP-A-SADDLE PRO™



SNAP-A-SADDLE PRO™ MULTI



ZBA Z-BRACKET

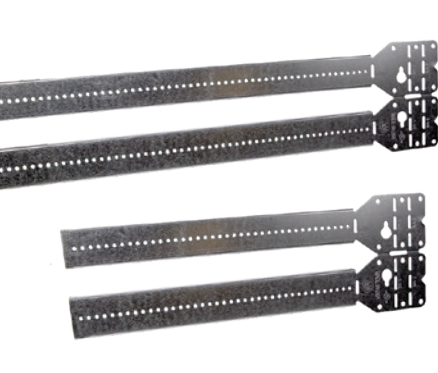

FITTINGS & ACCESSORIES

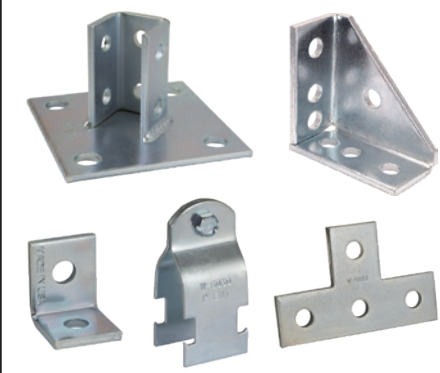

CUT-STRUT



Wesanco-ZSi.com | 800-323-7053

Zsi & Wesanco are part of the Ideal Tridon Group. Learn more at idealtridongroup.com



4347 E. University Drive • Phoenix, AZ 85034
 Tel: 888-927-2248 • Fax: 480-383-6493
customerservice@westerncomponentsales.com
www.westerncomponentsales.com

INSULATED TUBING & PIPE SUPPORTS PLUMBING COMPONENTS

CUSH-A-NATOR®



(CN) Standard Temp -50°F to 275°F
 (HT) High Temp -65°F to 340°F
 (HIT) High Intensity Temp -65°F to 400°F

CUSH-A-BLOCK® / MINI



GAMMA PADS

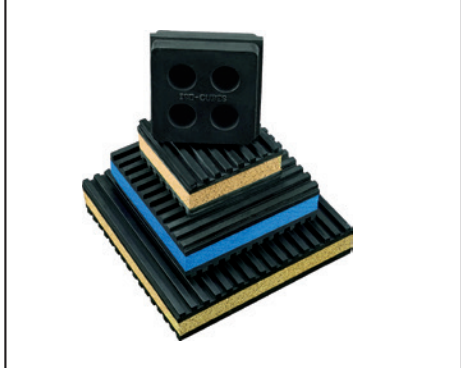

CUSH-A-THERM®

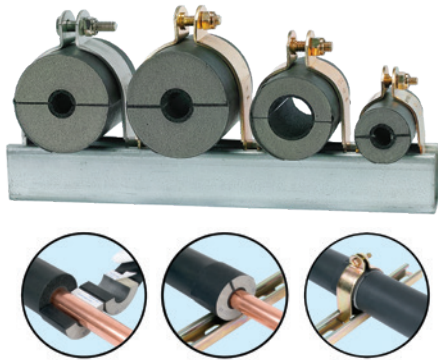

SNAP-A-SADDLE PRO™



SNAP-A-SADDLE PRO™ MULTI



ZBA Z-BRACKET

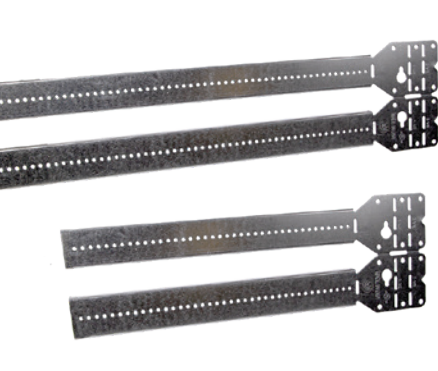

FITTINGS & ACCESSORIES

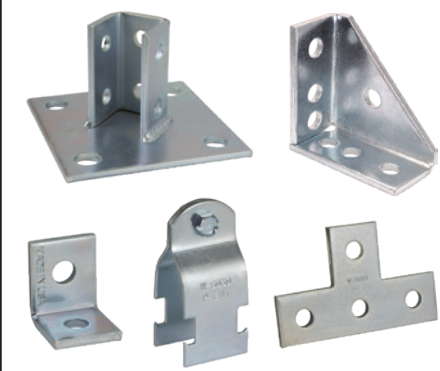

CUT-STRUT

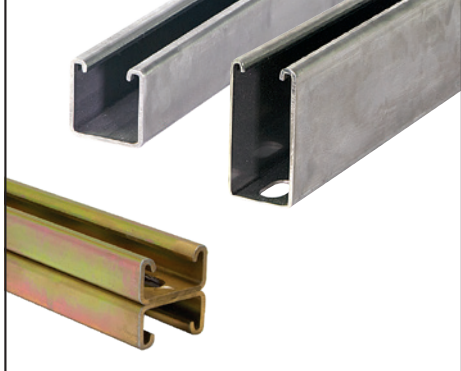

Wesanco-ZSi.com | 800-323-7053

ZSi & Wesanco are part of the Ideal Tridon Group. Learn more at idealtridongroup.com



Production Products Inc.
 317 Rivershire Ct.
 Lincolnshire, IL 60069
Jeff@productionproductsinc.com
 Tel: 847-302-3358



WESANCO

ZSI

INSULATED TUBING & PIPE SUPPORTS PLUMBING COMPONENTS

CUSH-A-NATOR®



(CN)	(HT)	(HIT)
Standard Temp	High Temp	High Intensity
-50°F to 275°F	-65°F to 340°F	Temp
		-65°F to 400°F

CUSH-A-BLOCK® / MINI



GAMMA PADS

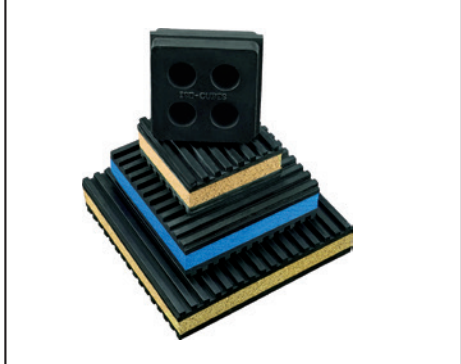

CUSH-A-THERM®

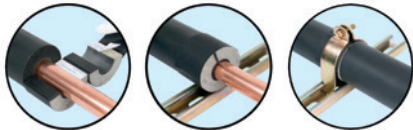
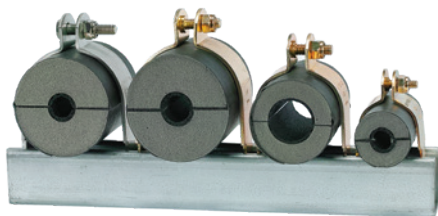

SNAP-A-SADDLE PRO™



SNAP-A-SADDLE PRO™ MULTI

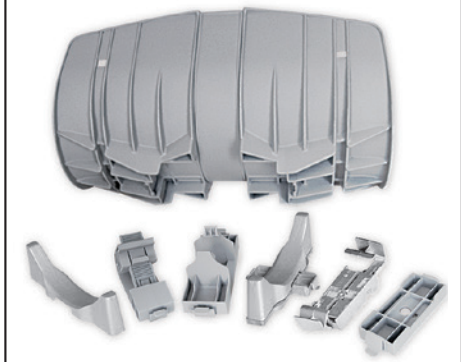

ZBA Z-BRACKET

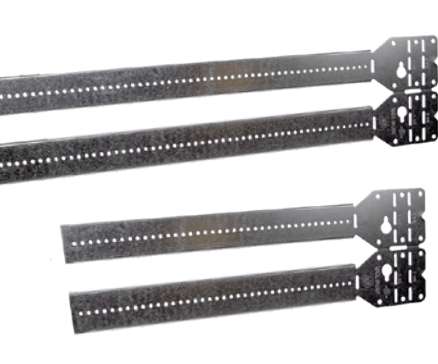

FITTINGS & ACCESSORIES

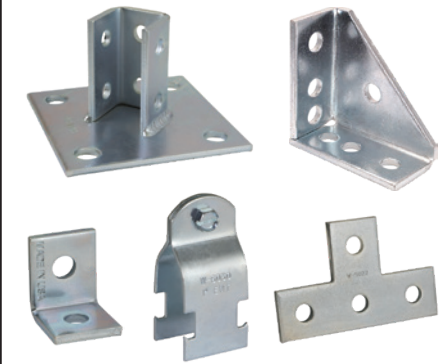

CUT-STRUT

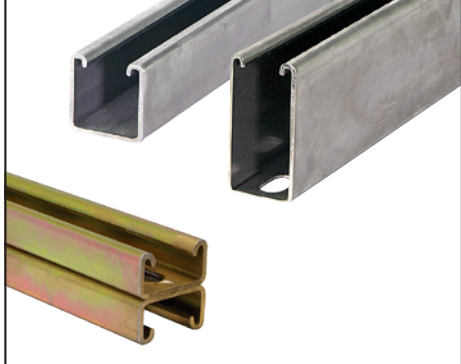

Wesanco-ZSi.com | 800-323-7053

ZSi & Wesanco are part of the Ideal Tridon Group. Learn more at idealtridongroup.com



W&R Industrial Products, Inc.
 828 Marie Ave • Martinez, CA 94553
 Ph: (925) 602-9700
 Direct: (925) 602-9704 • Cell: (925) 250-7678
 Email: wpruett@wnrind.com



WESANCO

ZSI

INSULATED TUBING & PIPE SUPPORTS PLUMBING COMPONENTS

CUSH-A-NATOR®



(CN)	(HT)	(HIT)
Standard Temp	High Temp	High Intensity
-50°F to 275°F	-65°F to 340°F	Temp
		-65°F to 400°F

CUSH-A-BLOCK® / MINI



GAMMA PADS

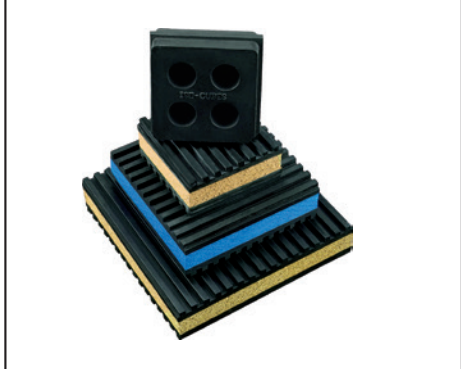

CUSH-A-THERM®

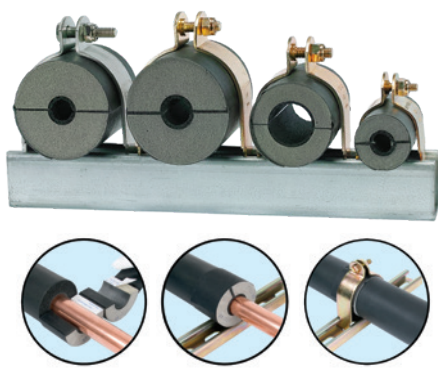

SNAP-A-SADDLE PRO™



SNAP-A-SADDLE PRO™ MULTI



ZBA Z-BRACKET

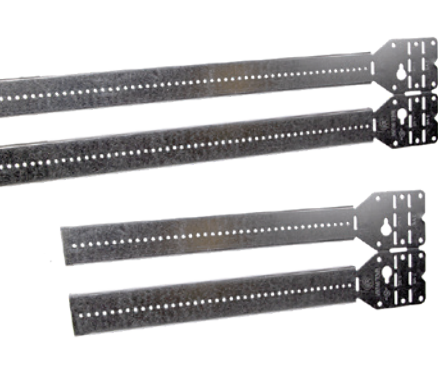

FITTINGS & ACCESSORIES

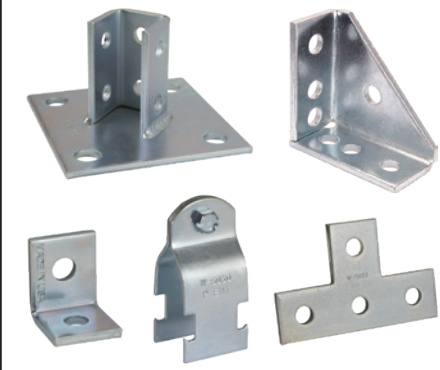

CUT-STRUT

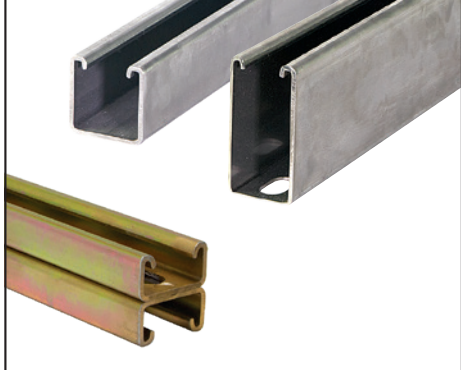

Wesanco-ZSi.com | 800-323-7053

ZSi & Wesanco are part of the Ideal Tridon Group. Learn more at idealtridongroup.com



Olympius Associates

Keith Bennett
 Olympius Associates
 Cell: (562) 445-9872 • Phone: (562) 921-4490
 FAX: (562) 921-7028
www.olympiusassoc.com



INSULATED TUBING & PIPE SUPPORTS PLUMBING COMPONENTS

CUSH-A-NATOR®



(CN) Standard Temp
-50°F to 275°F

(HT) High Temp
-65°F to 340°F

(HIT) High Intensity Temp
-65°F to 400°F

CUSH-A-BLOCK® / MINI



GAMMA PADS

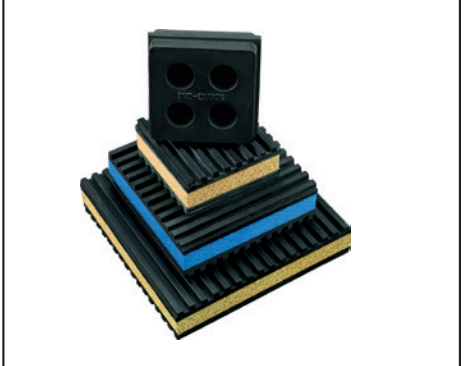

CUSH-A-THERM®

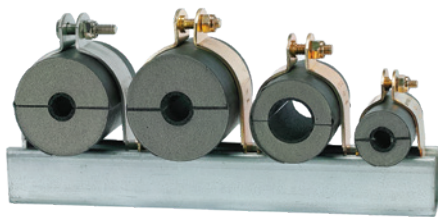

SNAP-A-SADDLE PRO™



SNAP-A-SADDLE PRO™ MULTI



ZBA Z-BRACKET

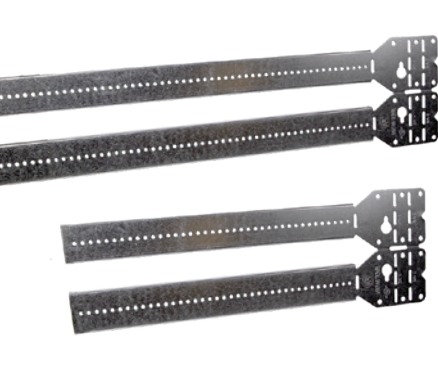

FITTINGS & ACCESSORIES

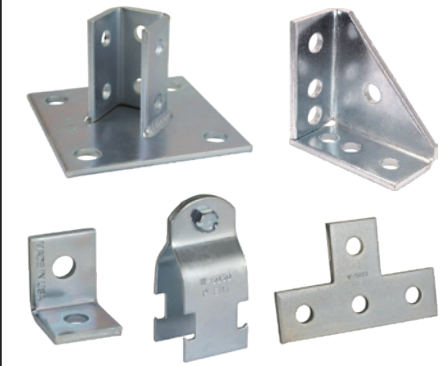

CUT-STRUT

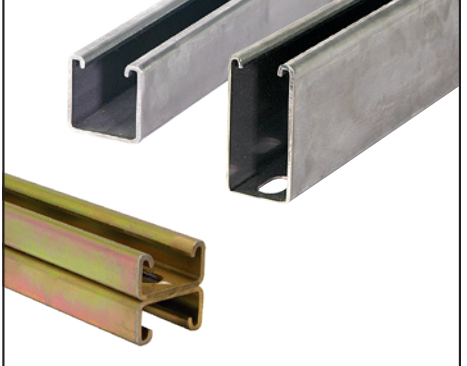

Wesanco-ZSi.com | 800-323-7053

ZSi & Wesanco are part of the Ideal Tridon Group. Learn more at idealtridongroup.com



FASTENAL®



WESANCO

ZSI

INSULATED TUBING & PIPE SUPPORTS HVAC REFRIGERATION COMPONENTS

CUSH-A-NATOR®



(CN)	(HT)	(HIT)
Standard Temp	High Temp	High Intensity
-50°F to 275°F	-65°F to 340°F	Temp
		-65°F to 400°F

CUSH-A-BLOCK®



CUSH-A-BLOCK® MINI

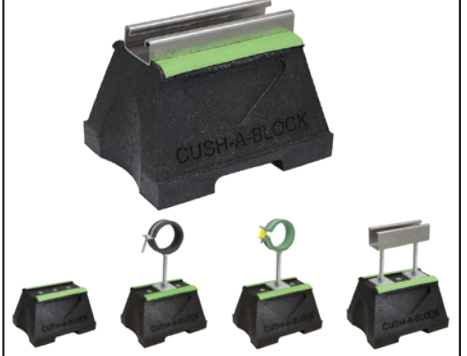

CUSH-A-THERM®

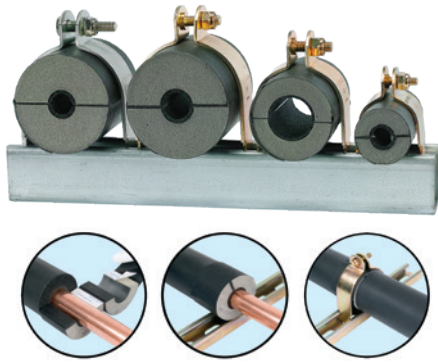

SNAP-A-SADDLE PRO™



SNAP-A-SADDLE PRO™ MULTI



LOOP CLAMPS



FITTINGS & ACCESSORIES

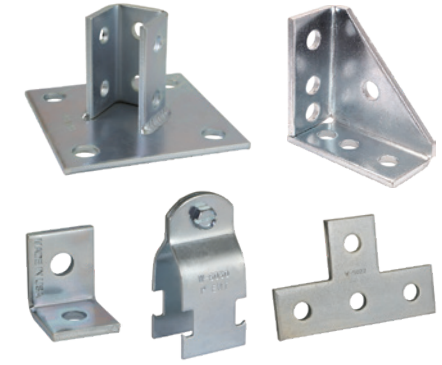

CUT-STRUT

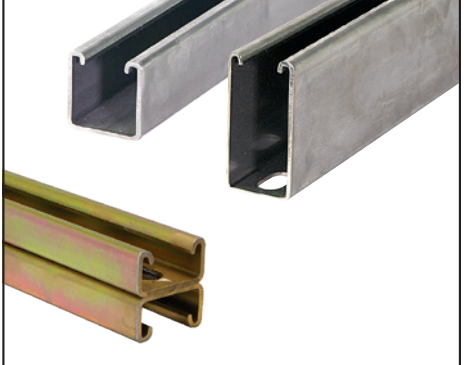

Wesanco-ZSi.com | 800-323-7053

ZSi & Wesanco are part of the Ideal Tridon Group. Learn more at idealtridongroup.com



FASTENAL®